

DeltaBase 525

Technical Data Sheet



Release Date: Feb 27th, 2008

Page 1 of 6

PRODUCT OVERVIEW

The DeltaBase 525 provides high drilling power in a very small package. This multipurpose drill has the ability to employ many different drilling methods making the DB525 an essential tool on today's jobsite.

Features:

- Heavy duty mast design and multi-speed drill heads allow for high torque drilling but also high speeds for coring when required
- Mounted on steel tracks for difficult terrain and optional radio remote control for driving
- Standard safety features including an interlocked safety cage and low speed, low torque rotation for management
- Options for on-board accessories including water pumps, Automatic SPT, and rod rack means that everything is on-site and ready to drill



STANDARD DRILLING SYSTEMS

	METRIC SYSTEM	US CUSTOMARY SYSTEM
CORE DRILLING		
NQ / NQ2" / NV / NV2"	310 m	1000 ft
HQ / HV	220 m	710 ft
PQ / PV	145 m	480 ft
SQ	90 m	290 ft
ROTARY DRILLING (TRICONE)		
Hole diameter - 216 mm (8.5 in)	175 m	570 ft
AUGER DRILLING		
Hole diameter - 150 mm	15-20 m	49-65 ft
DTH DRILLING PACKAGE		
Maximum Size DTH Hammer	98 mm (3 7/8") @ max 17,2 m ³ / min @ max 24 bar	
Maximum Depth Capacity	290 m	950 ft
Recommended Hole Size	115 mm	4.5 in
Maximum Hole Size	127 mm	5 in
Recommended Rod Size	76,1 mm	3 in

DTH SHOCK ABSORBER FOR ROTARY HEAD INCLUDED

Note: Air compressor must be selected according to hammer used.

In-line oiler and shock absorber are required for DTH drilling.

DeltaBase 525

Technical Data Sheet



Release Date: Feb 27th, 2008

Page 2 of 6

TECHNICAL SPECIFICATIONS

	METRIC SYSTEM	US CUSTOMARY SYSTEM
PRIME MOVER		
Standard	Deutz D914L04 air cooled engine, COM III	
Fuel	Diesel	
No. of Cylinders	4	
Swept Volume	4,31 l	263 cu. in
Power	53 KW @ 2300 rpm	71 hp @ 2300 rpm
Fuel Tank Capacity	60 l	16 gal
Specific Fuel Consumption	225 g/kWh	
Standard engine for work up to	1000 m @ 30°C 1700 m @ 0°C without power loss	
PRIME MOVER FOR HIGHER AMBIENT TEMPERATURE OR HIGHER ELEVATIONS - OPTIONAL EQUIPMENT		
Engine	Deutz BF4L914 air cooled engine, COM II	
Fuel	Diesel	
No. of Cylinders	4, turbocharged	
Swept Volume	4,31 l	263 cu. in
Power	72,4 kW @ 2300 rpm	97 hp @ 2300 rpm
Fuel Tank Capacity	60 l	16 gal
Specific Fuel Consumption	223 g/kWh	
Maximum altitude without power loss	53 kW - 1000 m @ 60°C, 2000 m @ 50°C, 3000 m @ 35°C, 4000 m @ 25°C, 5000 m @ 10°C	
ROTARY HEAD DD52		
Low Gear	4890-977 Nm / 48-250 rpm	3606-720 lb-ft / 48-250 rpm
High Gear	1859-371 Nm / 140-740 rpm	1371-273 lb-ft / 140-740 rpm
Bore - Inside Diameter	62 mm	2.44 in
Flushing Head - Inside Diameter	22 mm	0.87 in
Rotation Motors	Danfoss - variable / reversible with pressure remote	
Top Drive Flange	2 3/8" API Reg PIN	
Floating spindle and flushing head included		
Hydraulic motor at max/min displacement, diesel engine at 2200 rpm		
Gear Ratio - 1 st	7.68 : 1	
- 2 nd	2.92 : 1	
Rotary Head Carriage with side shift		
ROTARY HEAD HY79 - OPTIONAL EQUIPMENT		
Low Gear	6000 Nm / 35 rpm	4440 lb-ft / 35 rpm
High Gear	260 Nm / 800 rpm	272 lb-ft / 800 rpm
Bore - Inside Diameter	52 mm	2 in
Flushing Head - Inside Diameter	24 mm	1 in

DeltaBase 525

Technical Data Sheet



Release Date: Feb 27th, 2008

Page 3 of 6

TECHNICAL SPECIFICATIONS

	METRIC SYSTEM	US CUSTOMARY SYSTEM
ROTARY HEAD HY79 - OPTIONAL EQUIPMENT		
Rotation Motors	Parker V12-80 + Danfoss OMT 315	
Top Drive Flange	2 3/8" API Reg Box	
Gear Ratio	4.047:1	
Distance from Drilling Line to Chain	435 mm	17.12 in
Rotary Head carriage with side shift and tip-out		
HYDRAULIC SYSTEM		
Primary Pump	Parker bent axis, fixed displacement	
Maximum Flow	66 lpm @ 2200 rpm	17.5 gpm @ 2200 rpm
Maximum Pressure	250 bar	3626 psi
Secondary Pump	Cassappa gear pump	
Maximum Flow	59 lpm @ 2200 rpm	15.5 gpm @ 2200 rpm
Maximum Flow (2 nd)	48 lpm @ 2200 rpm	12.5 gpm @ 2200 rpm
Maximum Pressure	175 bar	2538 psi
Oil Tank Capacity	200 l	53 gal
DRILL MAST AND FEED SYSTEM		
Feed Stroke	4000 mm	13.2 ft
Feed Speed - up	12,5 m/min	41 ft/min
- down	18 m/min	59 ft/min
Fast Feed Speed - up	31 m/min	101 ft/min
- down	51 m/min	167 ft/min
Pull Down Force	34 kN	7673 lbf
Pull Back Force	55 kN	12364 lbf
Drilling Inclination	45° horizontal to 90° vertical down	
Mast Dump	1000 mm	3.3 ft
Rod Length	3000 mm max	9.84 ft max
MAIN WINCH PL 8		
Line Pull	30 kN	6744 lbf
Line Speed	20 m/min	65 ft/min
Cable Length, 13 mm	30 m	98.4 ft
ROD CLAMPS		
Maximum Diameter	220 mm	8.6 in
Maximum Clamping Capacity	175 kN	4500 lbf
Maximum Breaking Torque	20,5 kNm	15120 lb ft

DeltaBase 525

Technical Data Sheet



Release Date: Feb 27th, 2008

Page 4 of 6

TECHNICAL SPECIFICATIONS

	METRIC SYSTEM	US CUSTOMARY SYSTEM
UNDERCARRIAGE		
Type	Crawler mounted triple grouser steel tracks	
Maximum Driving Speed	1,5 km/h	1.0 mph
Axis Distance	1715 mm	67.5 in
Maximum Ground Pressure	0,053 MPa	7.7 psi
Climbing Capacity	(Grade ability 60%) approximately 30°	
Optional Undercarriage	Trailer Mounted, Skid Mounted	
MAST EXTENSION FOR LONGER ROD PULL		
Maximum Rod Pull	2 x 3 m (6m)	19.7 ft
Fitted onto standard mast to pull 6 m rod		
Rod Storage	30 pieces of 76 mm rods	
Towing Hook on Rear of Rig		
Air Connection on Rear of Rig for DTH Compressor		
OPTIONAL EQUIPMENT		
WIRELINE WINCH		
Line Pull	6,5 kN	1461 lbf
Line Speed	100 m/min	328 ft/min
Cable Length 6 mm	250 m	820 ft
MUD PUMP DP100		
Continuous Flow	90 l/min	23.7 gpm
Maximum Flow	100 l/min	26.4 gpm
Pressure	30 bar	435 psi
MUD PUMP DP200		
Continuous Flow	160 l/min	42 gpm
Maximum Flow	180-200 l/min	47-53 gpm
Pressure	30 bar	435 psi
Flushing Head with 42 mm ID included		
FMC PUMP LO918		
Flow	100 l/min	26 gpm
Pressure	45 bar	652 psi

DeltaBase 525

Technical Data Sheet



Release Date: Feb 27th, 2008

Page 5 of 6

TECHNICAL SPECIFICATIONS

	METRIC SYSTEM	US CUSTOMARY SYSTEM
SPT (STANDARD PENETRATION TEST) AUTO HAMMER		
Impact Rate	1-30 bpm	
Travel Length	762 mm	30 in
Hammer Weigth	63,5 kg	140 lb
CENTRALIZER - ROD GUIDE		
Exchangable Inserts for Rods	76, 89, 114, 127, 140, 168, 193, 220 mm (Choose required sizes)	
OIL LINE LUBRICATOR FOR DTH DRILLING		
Oil Tank Capacity	20 l	5.3 gal
HIGH TEMPERATURE OIL COOLER		
Upgraded oil cooler for ambient temperature over 35° C (95° F)		
NIGHT LIGHTS		
No. of Pieces	4	
JAW BODY FOR CLAMP AND BREAK OUT FOR CORING		
Jaw Plates for Coring	BQ / BW	
(choose required sizes)	NQ / NW	
	HQ / HW	
	PW	
MIST PUMP		
Flow	30 l/min	8 gpm
Pressure	200 bar	2900 psi
ACCESSORIES		
Auxiliary Work Vice	180 mm wide, 220 mm long, 120 mm deep clamp, rotating mounting base and seperate rod support work bracket	
Remote Control	Radio remote control for driving	
Auxiliary Diesel Filling Pump	Electric powered diesel filling pump	
Data Logger Couplings	3 Couplings for data logger (feed pressure, rpm, mud pump pressure)	
Instrument Vandal Covers	Lockable covers for control panels and instruments	
Rubber Crawler Pads	Full set (76 pcs)	
Tool Box	With necessary set of tools for basic maintenance and lubrication	
Environmental oil in hydraulic system		

DeltaBase 525

Technical Data Sheet



Release Date: Feb 27th, 2008

Page 6 of 6

DIMENSIONS AND WEIGHTS*

WEIGHT

Operational Weight = 6500 kg (14330 (approx.)

Dry Weight = 6200 kg (13670 lb)

Consisting of:

Diesel Power Unit Group DEUTZ D914L04 4.10 litre 4 cylinder

Hydraulic Module

Main Winch c/w Cable

Hydraulic Mast Raising (Independent)

Lower Mast Assembly

Levelling Jacks (Hydraulic)

Rotary Head

Crawler - triple grouser type

Battery

Foot Clamp and Breaking Clamp

MEASUREMENTS

UNDERCARRIAGE

Width = 1900 mm (74.8 in)

Pad width = 300 mm (11.8 in)

Weight = 1035 kg (2280 lb)

SPT

Hammer weight = 63,5 kg (140 lb)

Drop stroke = 760 mm

Total weight = 180 kg (397 lb)

DB525 WITH ROTARY HEAD HY79

Height = 2785 mm (109.5 in)

Width = 1950 mm (76.7 in)

Mast length = 6700 mm (263.5 in)

Complete height = 7970 mm (313.5 in)

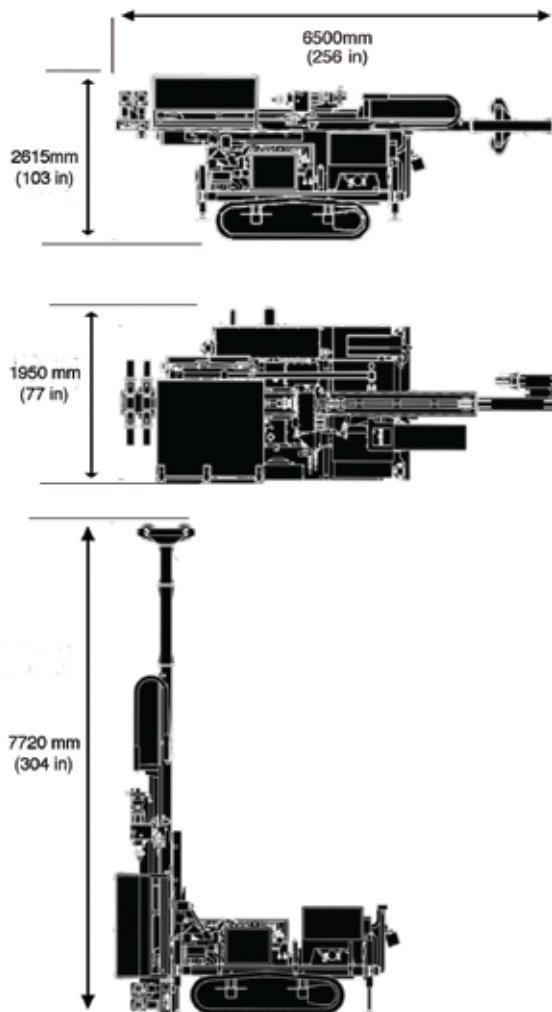

* Dimensions and weights may vary depending on options and should be checked before starting an operation.