

LMA90 Power Pack and Control Panel

Input Power

Electric Motor Rating	90kW (120 hp)
-----------------------	---------------

Hydrostatic Pumps**Main Pump****Recirculation Pump**

Application

All Drill Functions

Oil cooling and filtration
Charge for main pump

Type

Variable Displacement
Axial Piston with pressure
compensated load sensing control

Gear Fixed displacement

Manufacturer

Rexroth

Rexroth

Normal operating speed

1450 rpm (50 Hz) or 1750 rpm (60 Hz)

Maximum operating conditions
as used on LMA90285 bar (5000 psi)
180 lpm (47.6 U.S. gal/min)5 bar (70 psi)
80 lpm (21 U.S. gal/min)

Hydraulic tank volume

150 L (40 U.S. gal)

Oil Cooling

Type

Water over oil

Electrical Control System

Control voltage

24 volts

Control type

Allen-Bradley PLC

TECH DATA

DIAMOND CORE DRILLING

LMA90 Power Pack and Control Panel

Power Pack

Approx. weight	1650 kg (3630 lb) incl. electric motor and starter but without towing group
----------------	---

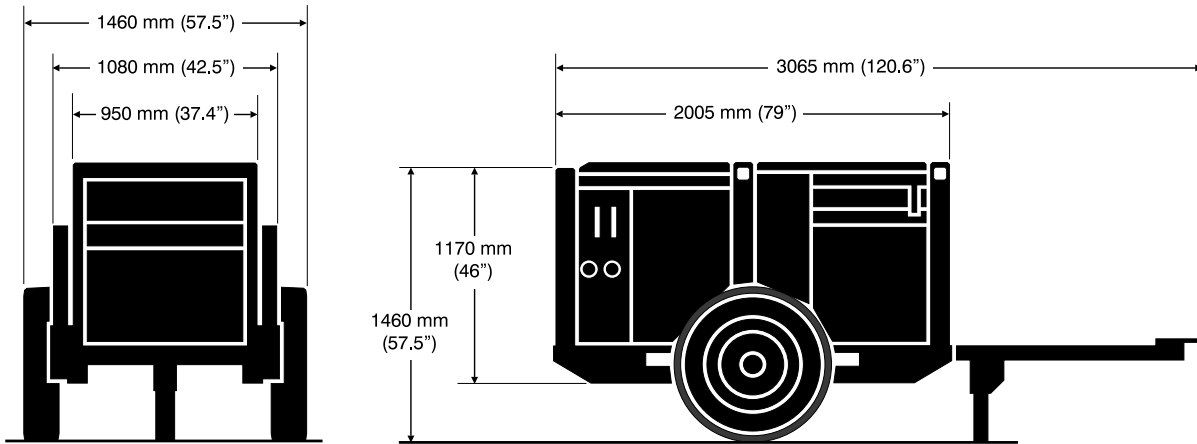

Control Panel

Approx. weight	41 kg (90 lb) without cables and stand
----------------	--

