

## SECAN® S250 - Jackleg/Sinker Drill

### DRILLING DEPTH GUIDELINES

The figures in these tables have been calculated, based on field experience, and may be reasonably expected.

Actual drilling capacity will depend on in-hole tools and conditions, drilling techniques and equipment used.

	METRIC SYSTEM	U.S. CUSTOMARY SYSTEM
<b>ROCKDRILL SPECIFICATION:</b>		
<b>Bore</b>	79.4 mm	3.126 in
<b>Stroke</b>	73.25 mm	2.884 in
<b>Blows/Minute</b>	2200 @ 6.2 bar	90 psi
<b>Air Consumption</b>	4.4 m <sup>3</sup> /min @ 6.2 bar	175 cfm @ 90 psi
<b>Air Connection</b>	–	1 in BSP
<b>Water Connection</b>	–	1/2 in BSP

### SUPPLY HOSE ID (required):

<b>Air</b>	25 mm	1 in
<b>Water</b>	12 mm	1/2 in

### STEEL SIZE (HEX) - CHUCK END:

<b>Standard</b>	108 x 22 mm	4-1/4 x 7/8 in
<b>Optional</b>	108 x 25 mm	4-1/4 x 1 in

### STANDARD SECAN S250 AIRLEG (sold seperately):

<b>Bore Diameter</b>	68 mm	2.677 in
<b>Stroke Length</b>	1295 mm	51 in
<b>Thrust</b>	230 kg at 6.2 bar	506 lb @ 90 psi

### OPTIONAL SECAN S250 AIRLEG (sold seperately):

<b>Stroke Length</b>	991 mm	39 in
<b>Stroke Length</b>	762 mm	30 in

## SECAN® S250 - Jackleg/Sinker Drill

		METRIC SYSTEM	U.S. CUSTOMARY SYSTEM
<b>NOISE EMISSIONS*</b>			
<b>Muffled</b>	- Noise Pressure	113.5 dB(A)	
	- Power	126.5 dB(A)	
<b>Unmuffled</b>	- Noise Pressure	116.0 dB(A)	
	- Power	129.0 dB(A)	

**NOTE:** Noise levels are measured in accordance with ISO3744 and SANS1470 (Part 4).

\* Boart Longyear has done extensive research and testing in noise reduction and have found that a proper hearing conservation program is an effective means of dealing with elevated noise levels.

## SECAN® S250 - Jackleg/Sinker Drill

### DIMENSIONS AND WEIGHTS \*

#### JACKLEG

##### Weight (less airleg)

Muffled 42.2 kg (93 lb)

Unmuffled 41.3 kg (91 lb)

#### STANDARD AIRLEG

Weight 15.5 kg (34 lb)

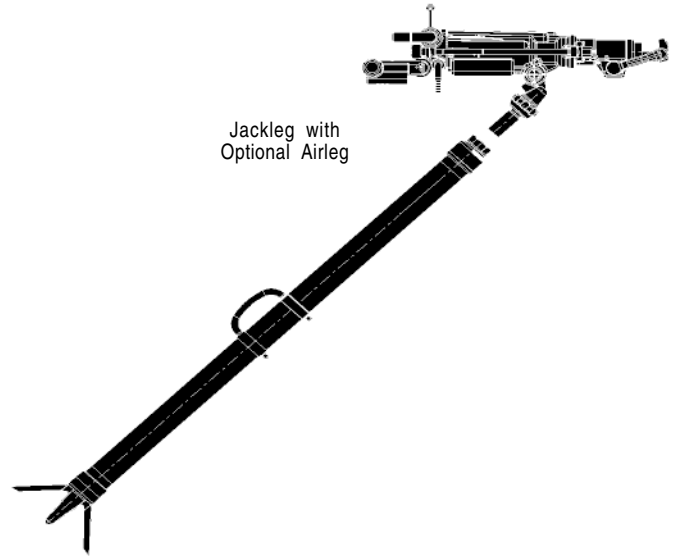

#### SINKER

##### Weight

Muffled 36.8 kg (81lb)

Unmuffled 35.9 kg (79 lb)

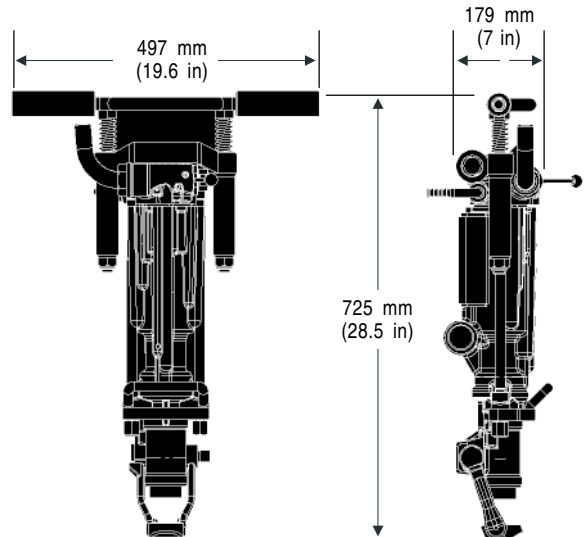

\* Dimensions and weights may vary depending on options and should be checked before crating or lifting.

## SECAN<sup>®</sup> S250 - Jackleg/Sinker Drill

### ACCESSORIES

#### FOOTBALL STYLE LUBRICATOR

4 hours drilling capacity with S250 rockdrill

Install in line, within 3.5 m (12 ft) of rockdrill

**Weight :** 4.8 kg (10.6 lb)

**Capacity:** 600 mL (36.6 in<sup>3</sup>) rockdrill oil

**Min/Max Adjustment:** 1/4 turn

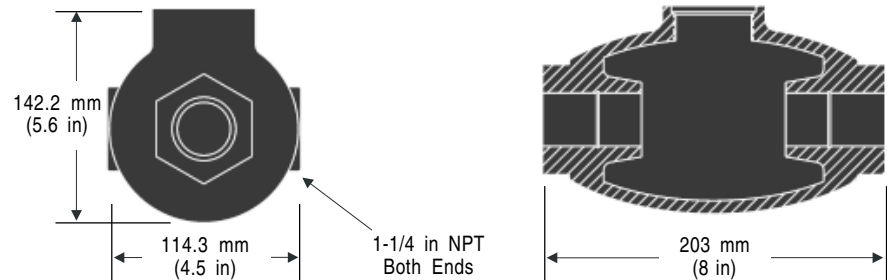

\* Dimensions and weights may vary depending on options and should be checked before crating or lifting.